

Agilent 8924C

CDMA Mobile Station Test Set

Product Note

Contents

Section 1—Introduction	1
Test Parameters	2
Base Station (Test Set) Power Transitions	2
References	2
Section 2—Test Equipment	3
Section 3—Connecting the Equipment	4
References	4
Section 4—Test Procedure	5
Section 5—Configuring the Test Set	8
Setting the RF Level Offset	8
Setting the Pilot and Traffic Channels	8
Setting the Channel and Protocol	10
Setting the CDMA Transmitter Power	10
Test Mode	11
Section 6—Setting Up a 20 dB Increment on the Test Set	12
Section 7—Determining the Test Set’s Trigger Time Delay	12
Section 8—Configuring the Spectrum Analyzer and Software	14
Setting “CDMA Config” Options	14
Setting the RF Channel Function	15
Setting the Time Response Function	15
Appendix 1—Background on Open and Closed Loop Power Control	16
Open Loop	16
Closed Loop	16
Appendix 2—The Effect of Closed Loop Control on the Open Loop Test	17
Appendix 3—Determining Cable Connection Losses	18
External Power Meter Method	18
Using the Agilent 8924C Test Set	18
Appendix 4—Trigger Signal Description	19
Making a Trigger Cable	20
Trigger Signal Description	19
Reference	19

Open Loop Power-Control Time-Response Test

This product note will help you measure the “time response of open loop power control” for a CDMA mobile cellular telephone. The equipment and procedures in this document apply to CDMA mobile cellular telephones based on TIA/EIA/IS-95-A, or related industry standards.

Section 1—Introduction

The open loop power control time-response is defined as the amount of time (t) it takes the mobile phone to respond to and acquire equilibrium following a step increase in base station power, ΔP_{in} .

This test verifies that the mobile is capable of adjusting its transmit power throughout its dynamic range of transmission within a power versus time mask determined by applicable standards.

An example of this mask, with a $\Delta P_{in} = 20$ dB and $\Delta t = 100$ ms, is shown in Figure 1. For TIA/EIA/IS-95-A, the upper and lower limits of this mask are determined by the equations shown on the following page.



Agilent Technologies

Innovating the HP Way

Upper Limit Equations

For: $0 < t < 24$ ms: $\text{Max} [1.2 \times |\Delta P_{in}| \times (t/24), |\Delta P_{in}| \times (t/24) + 2.0 \text{ dB}] + 1.5 \text{ dB}$

For: $t \geq 24$ ms: $\text{Max} [1.2 \times |\Delta P_{in}|, |\Delta P_{in}| + 0.5 \text{ dB}] + 1.5 \text{ dB}$

Lower Limit Equation

For: $t \geq 0$ ms: $\text{Max} [0.8 \times |\Delta P_{in}| \times [1 - e^{(1.25-t)/36}] - 2.0 \text{ dB}, 0] - 1 \text{ dB}$

Where:

- t is expressed in milliseconds,
- ΔP_{in} is expressed in units of dB
- $\text{Max} [x, y]$ is the maximum of the x and y components in the upper and lower limit equations.

Test Parameters

The following are general test parameters for the open loop power control time-response test (from industry standard IS-98-A, other standards should be similar).

- Test set power range into phone's receiver: -25 dBm to -104 dBm
- Pilot channel level: -7 dB
- Traffic channel level: -7.4 dB

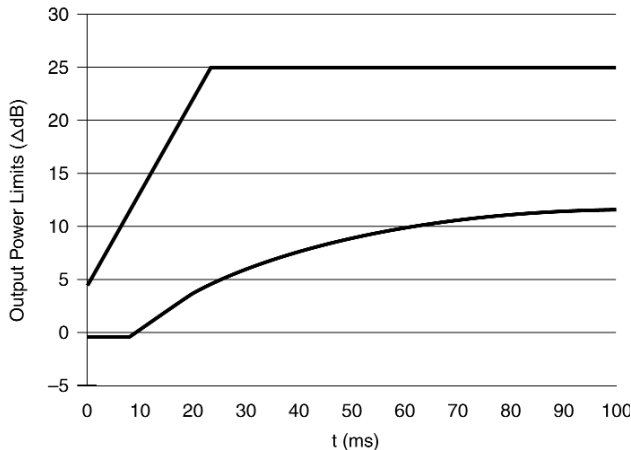

Figure 1. Example Limits for the Open Loop Response

Base Station (Test Set) Power Transitions

1. The open loop power control time-response test is initiated at a power level of -60 dBm (base station). See Figure 2.
2. The test set power is increased by a step of 20 dB to a power level of -40 dBm.
3. The test set power is decreased by a step of 20 dB to a power level of -60 dBm.
4. The test set power is decreased by a step of 20 dB to a power level of -80 dBm.
5. The test set power is increased by a step of 20 dB to a power level of -60 dBm.

References

- Telecommunications Industry Association, Industry Standards TIA/EIA/IS-98-A (Section 10.4.2—Time Response of Open Loop Power Control), Sept. 10, 1997
- American National Standards Institute (ANSI). ANSI J-STD-018 Recommended Minimum Performance Requirements for 1.8 to 2.0 GHz Code Division Multiple Access (CDMA) Personal Stations (Section 4.4.2—Time Response of Open Loop Power Control)
- ARIB STD-T53 Ver. 1.0, CDMA Cellular System, Association of Radio Industries and Business, 1-4-1 Kasumigaseki, Chiyoda-ku, Tokyo 100, Japan, October 1997

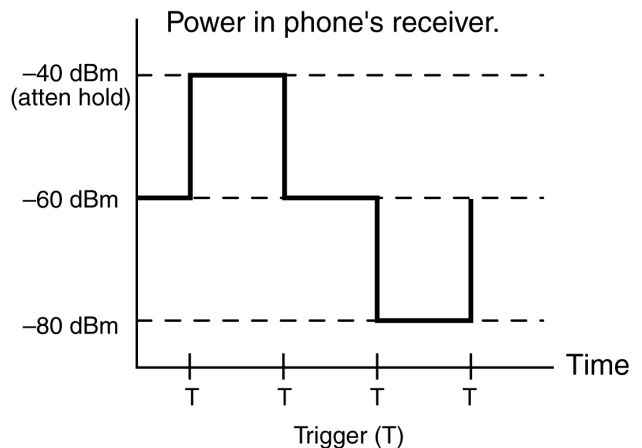

Figure 2. Base Station Power Transitions

Section 2—Test Equipment

Equipment	Notes
8924C CDMA Mobile Station Test Set	<p>The Test Set must be equipped with electronic attenuators. NOTE: To determine if the Agilent 8924C Test Set is equipped with an electronic attenuator, access the Test Set's TESTS screen (this procedure will erase any other IBASIC program stored in the test set):</p> <ol style="list-style-type: none"> 1. Press the TEST key. 2. Select Procedure Location: ROM. 3. Select Procedure Filename: ICONFIG3. 4. Press k1 (Run Test) and look for A5 Input with Electronic Attenuator.
83236B PCS Interface	This PCS interface is needed if performing PCS band tests
<p>One of the following Agilent Technologies spectrum analyzers is needed:</p> <ul style="list-style-type: none"> • 8593E Spectrum Analyzer • 8594E Spectrum Analyzer • 8595E Spectrum Analyzer • 8596E Spectrum Analyzer 	<p>MINIMUM REQUIRED OPTIONS for 85725C open loop measurements:</p> <ul style="list-style-type: none"> • Option 004—Precision Frequency Reference (or equivalent external 10 MHz precision frequency reference) • Option 101—Fast Time Domain Sweeps (if Option 151 is installed DO NOT INSTALL Option 101) <p>PREFERRED and RECOMMENDED OPTIONS for 85725C:</p> <ul style="list-style-type: none"> • Option 140—Narrow Resolution Bandwidth and Precision Frequency Reference (narrow bandwidth for ACPR measurements; includes precision reference same as Option 004) • Option 053—Improved CDMA Amplitude Accuracy (for cellular and PCS bands) • Option 151—DSP, Fast ADC, and Digital Demodulator (provides faster CDMA measurements) • Option 160—CDMA firmware (for use with option 151) <p>OTHER SUGGESTED OPTIONS:</p> <ul style="list-style-type: none"> • Option 041—GPIB and Parallel Interface • Option 105—Time-Gated Spectrum Analysis <p>To determine which spectrum analyzer option is installed in the spectrum analyzers:</p> <ol style="list-style-type: none"> 1. Press CONFIG key. 2. Press More 1 of 3 softkey. 3. Press SHOW OPTIONS softkey.
85725C CDMA Measurements Personality	This assembly is installed in the 859XE spectrum analyzer.
CDMA Mobile Phone	An appropriate antenna connector or cable is required for the phone.
Shielded RF Isolation Box	This item is optional but recommended.
Power Splitter	A resistive or transformer-coupled power splitter is acceptable. It must be able to handle the output power of the phone (approximately 25 dBm max). Example: Mini-Circuits resistive power splitter/combiner, p/n ZFRSC-2050 (dc to 2 GHz).
Trigger Cable	Use a 15-pin male D-connector to BNC male connector cable. This cable is used to send trigger signals to the 859XE Spectrum Analyzer from the 8924C Test Set. NOTE: See Appendix 5 in this document for instructions on how to build this cable.
RF Cable	Three low-loss shielded RF cables with type-N (male) connectors to mate with the power splitter, RF shielded box, and CDMA telephone.

Section 3—Connecting the Equipment

For CDMA cellular band mobile phones see Figure 3; for CDMA PCS band mobile phones see Figure 4.

1. Connect the CDMA phone to the power splitter. Ensure that the CDMA phone is properly shielded against external RF interference. An example of interference is an active base station transmitting on the same channel as the mobile unit under test.
2. Connect one output end of the power splitter to the 50 W input of the spectrum analyzer.
3. Connect the other output end of the power splitter to the RF IN/OUT port on the test set for cellular frequencies; or, to the RF IN/OUT port on the PCS interface for PCS frequencies.
4. Connect the trigger cable from the AUX CONTROL port (15-pin D-connector) on the back of the test set to the EXT TRIG INPUT (TTL) BNC-connector on the back of the spectrum analyzer. A trigger signal is required to activate the open loop test once it has undergone a step change in power. For instructions on making a trigger cable, see *Appendix 5—Trigger Cable and Trigger Signal Description*.

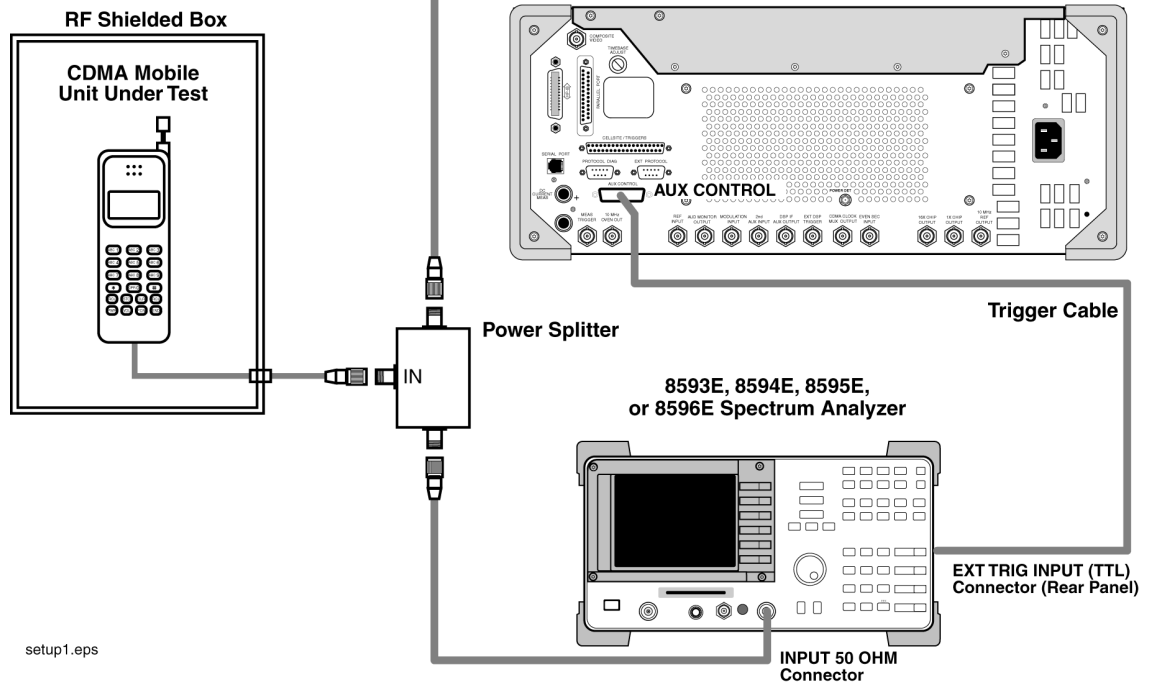
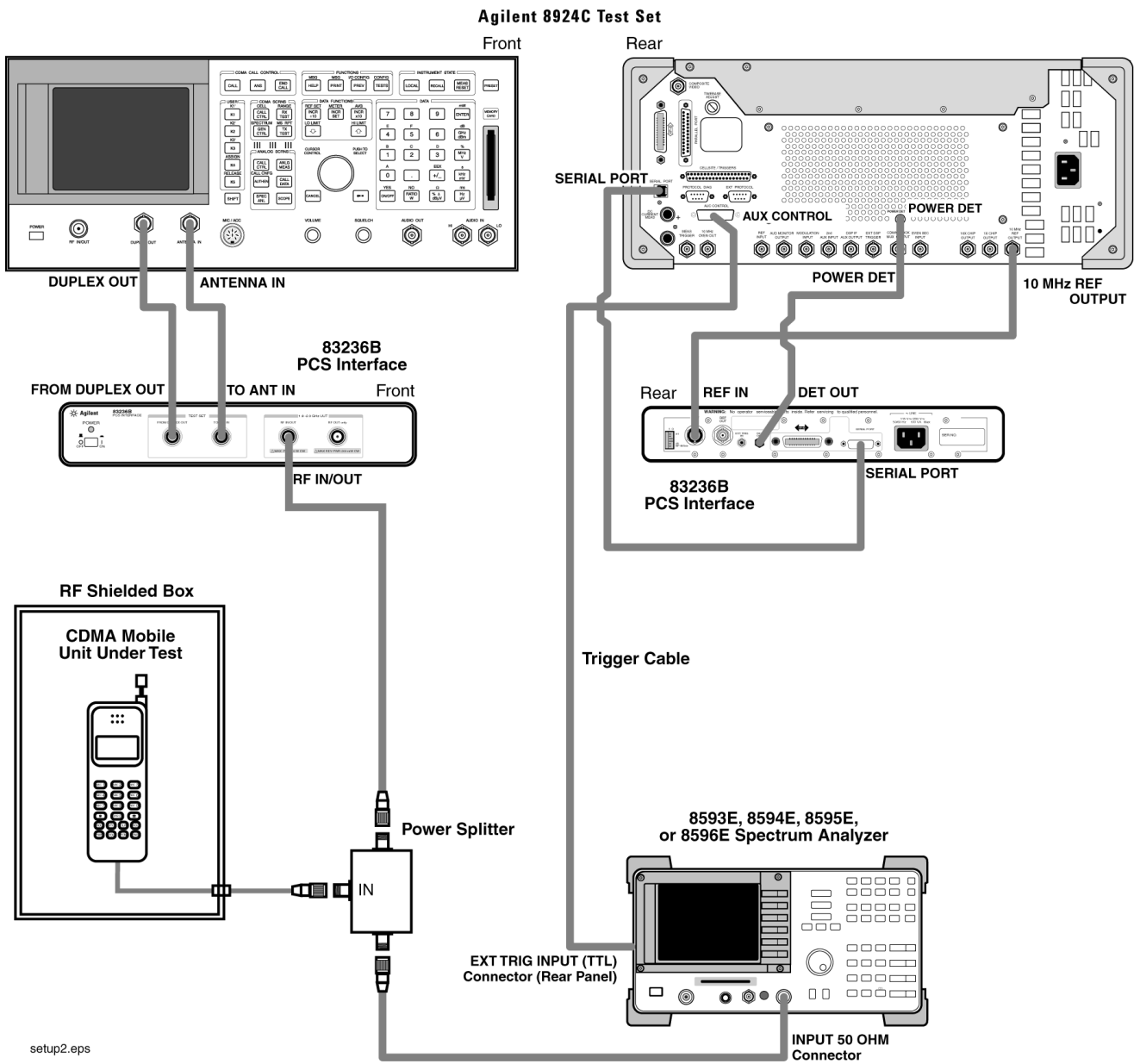

Figure 3. Setup for Cellular Band Phones

References

- *Agilent Technologies E8285A CDMA Mobile Station Test Set Reference Guide*, Chapter 2, Description of Connectors (SA TRIG OUTPUT), pub. number E8285-90018
- *Agilent Technologies 859XE Users Guide*, pub. number 08590-90301
- *Agilent Technologies 85725X CDMA Measurements Personality User's Guide*, pub. number 85725-90010



setup2.eps

Figure 4. Setup for PCS Band Phones

Section 4—Test Procedure

This section is a step-by-step measurement procedure. Some of the following steps will refer you to other sections in this document. After you complete the instructions in those sections, return to this section to continue the procedure.

1. Connect equipment as described in *Section 3—Connecting the Equipment*. Power-up the instruments but not the mobile phone.
2. Configure the test set as described in *Section 5—Configuring the Test Set*.
3. Set the RF power increment to 20 dB on the test set as described in *Section 6—Setting Up a 20 dB Increment on the Test Set*.
4. Calibrate channel power on the test set by accessing the CDMA TRANSMITTER POWER RANGE TEST screen (see Figure 5 item 6). For details refer to section 5, the subsection titled “Setting the CDMA Transmitter Mode.”

5. Measure the delay between the test set’s trigger signal and power transmission step using the spectrum analyzer as described in *Section 7—Determining the Test Set’s Trigger Time Delay*.

Record the trigger delay of the test set. Then convert the value from milliseconds to microseconds (milliseconds x 1000 = microseconds). It will be entered into the spectrum analyzer’s **DELAY** field.

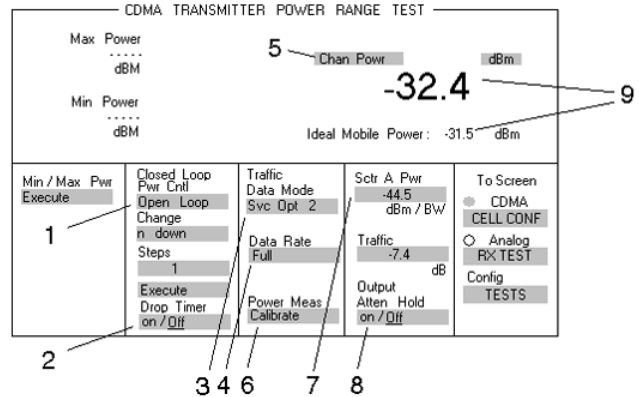

Figure 5. CDMA TRANSMITTER POWER RANGE TEST Screen

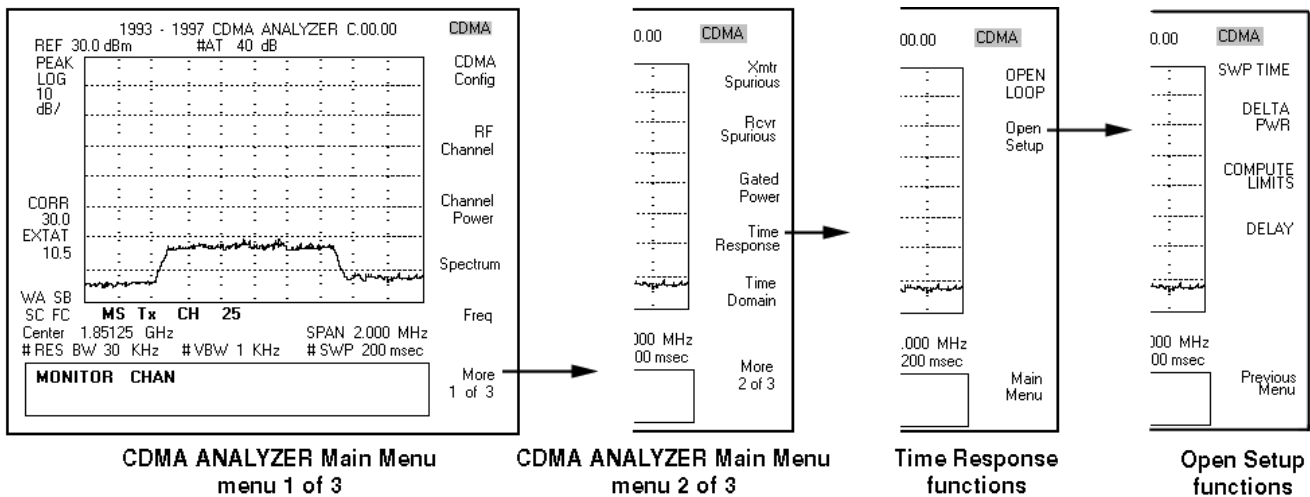

Figure 6. Time Response and Open Setup Functions

6. Configure the spectrum analyzer and software as described in *Section 8—Configuring the Spectrum Analyzer and Software*. Enter the recorded delay time into the **DELAY** field of the **Time Response/Open Setup** function, see Figure 6.
7. Turn on the CDMA phone. On the test set's CDMA TRANSMITTER POWER RANGE TEST screen, set the following:
 - 7a. Set **Closed Loop Pwr Cntl** field to **Closed Loop** (see Figure 5, item 1).
 - 7b. Set **Sctr A Pwr** field set **-40 dBm** (see Figure 5, item 7).
 - 7c. Set **Output Atten Hold** field (see Figure 5, item 8) to **Off**.
 - 7d. Set **Traffic Data Mode** to **Svc Opt 1** (see Figure 4, item 3, *this will be changed to Svc Opt 2 in step 9*), or to normal voice-call service option for the phone type.
8. Select the test set's CDMA CALL CONTROL screen. After the phone indicates service, dial a number and place a call from the phone to the test set. Wait until the call is connected.
9. Press the test set's END CALL key.
 - 9a. Set the **Traffic Data Mode** to **Svc Opt 2**
 - 9b. Press the test set's CALL key to connect a call in data loopback mode at full rate. (The phone will usually display a message indicating LOOP MODE.)
10. Once a call is connected, go to the CDMA TRANSMITTER POWER RANGE TEST screen on the test set and:
 - 10a. Change the **Closed Loop Pwr Cntl** field from **Close Loop** to **Open Loop** (see Figure 5, item 1).
 - 10b. Change the **Output Atten Hold** field to **on** (see Figure 5, item 8).
 - 10c. Change the **Sctr A Pwr** field to **-60 dBm** (see Figure 5, item 7). Remember to use up and down arrows.

11. On the spectrum analyzer, on the Time Response screen (see Figure 6), select the **OPEN LOOP** softkey. This will start the open loop time-response test. The message **Waiting for Ext Trig** appears on the screen (see Figure 7) after a short delay
12. Press the **SET REF LVL** softkey (see Figure 7, item 2). Enter 15 dBm. Press the ENTER key. This adjusts the spectrum analyzer's input attenuator and reference level to allow viewing of the full range of power transitions.
13. Step increase **Sctr A Pwr** field to **-40 dBm**. The time response will be displayed on the spectrum analyzer.

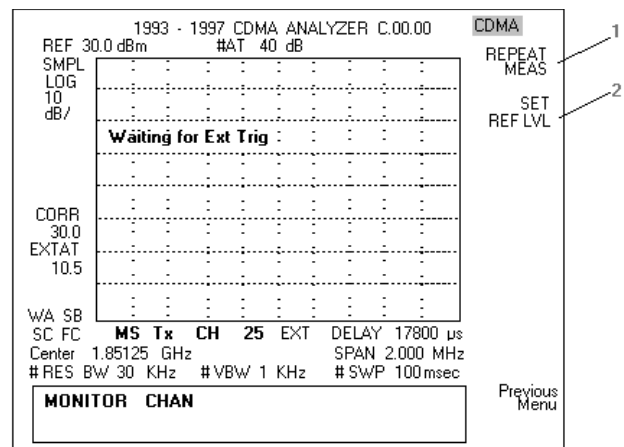

Figure 7. Spectrum Analyzer Waiting for External Trigger

14. A 20 dB step change of the test set's power will trigger the time response test. Figure 8 shows the results of a 20 dB decrease in the test set's transmitted power. Note that PASS or FAIL is displayed in the lower right corner.
15. Step decrease **Sctr A Pwr** field to **-60 dBm**. The new time response will be displayed on the spectrum analyzer.
16. Step decrease **Sctr A Pwr** field to **-80 dBm**. The new time response will be displayed on the spectrum analyzer.
17. Step increase **Sctr A Pwr** field to **-60 dBm**. The new time response will be displayed on the spectrum analyzer.

NOTE: The **REPEAT MEAS** softkey on the spectrum analyzer can be used to reinstate the open loop test (see Figure 8). However the open loop test will automatically reset for another measurement, so this softkey does not have to be pressed.

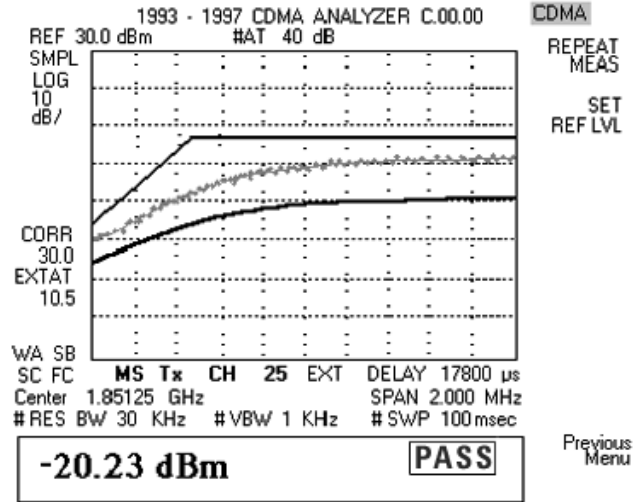

Figure 8. Spectrum Analyzer—Open Loop Response Test Results

Section 5—Configuring the Test Set

As an example, the following test set screens show the appropriate settings for testing a U.S. PCS phone. The screens presented are accurate with respect to firmware revision A.05.30. Future revisions will be similar but are not guaranteed to be the same.

Setting the RF Level Offset

Access the CONFIGURE screen, see Figure 9.

1. The **RF Level Offset** field must be **On** in order to activate the **RF In/Out** field (item 2).
2. The **RF In/Out** field should be set to the attenuation value determined by the methods described in *Appendix 3—Determining Cable Connection Losses*. This will compensate for losses encountered by the power splitter and cables. This value is entered as a negative offset (loss).

Range Hold Auto All Hold All	Intensity 7	CONFIGURE RF Display Freq/Chan	RF Level Offset On / Off	Firmware A.05.30
State: Mixed Beeper Quiet	Date 91397 MMDDYY		RF Chan Std US PCS	RF In / Out -7.4 dB
RX/TX Cntl Auto / Manual Carrier/ PTI	Time 15.33 HH.MM	Alt Chn Std None	RF Out only 0.0 dB	Serial No. 0000000000
Notch Coupl AFGenI / None	External Reference 10.0000 MHz	PCS Mode On / Off	Output Port RF Out / only	To Screen CDMA CELL CONF
Input Atten Auto / Hold 0 dB	Frame Clock 2.00 s		Rf Gen Lvl Calibrate	Analog RX TEST
RFGen Volts 50 ohm / emf				Config TESTS SERVICE

Figure 9. CONFIGURE Screen

Setting the Pilot and Traffic Channels

Access the CDMA GENERATOR CONTROL screen, see Figure 10.

1. For sector A (the left column on the screen), the **Pilot** channel field (Walsh channel 0) must be set to **-7.0 dB** (for testing EIA/TIA/IS-98-A).
2. The **Traffic** channel (Walsh channel 8 through 31 or 33 through 63) must be set to **-7.4 dB** (for testing to EIA/TIA/IS-98-A).

Sctr A Pwr -44.5 dBm / BW		Sctr B Pwr Off		AWGN Off	
1	Pilot -7.0 dB	Walsh 0	Pilot -7.0 dB	Walsh 0	RF Power -44.50 dBm / BW
	Sync -16.0 dB	32			To Screen CDMA CELL CONF Analog RX TEST Config TESTS
	Paging -12.0 dB	1			
2	Traffic -7.4 dB	8	Traffic -16.0 dB	12	
	OCNS -2.8925 dB	17	OCNS -1.1178 dB	42	
	PN Offset 12		PN Offset 36		

Figure 10. CDMA GENERATOR CONTROL Screen

Setting the Channel and Protocol

Access the CDMA CALL CONTROL screen, see Figure 11.

1. Set the **RF Chan Std** field (item 3) to the appropriate standard.
 - 1a. For example, for U.S. PCS frequencies, set this field to **US PCS**.
 - 1b. For U.S. cellular frequencies, set this field to **MS AMPS**.
 - 1c. For CDMA phones for use in Japan, choose **Japan CDMA**. The **RF Channel** field is automatically updated with the starting channel within the given standard.

2. Enter the appropriate channel value in the **RF Channel** field (item 1). The manufacturer or service provider programs the phone to the appropriate RF channels. If the RF channel is not known or incorrectly entered into the test set, the phone will start to scan all the possible channels in the phone's channel list. If an outside base station of higher power is received, the phone will lock onto it and discontinue its search. For some phones, this is a long process, therefore, it is recommended that the appropriate channel value is known and entered into the **RF Channel** field.

3. Enter the appropriate protocol for the selected channel standard into the **Protocol** field (item 2). For example:
 - 3a. For U.S. CDMA PCS frequencies, select **JSTD-008**.
 - 3b. For U.S. CDMA cellular frequencies, select **IS-95A** or **TSB-74**.
 - 3c. For Japanese CDMA, select **ARIB T53**.

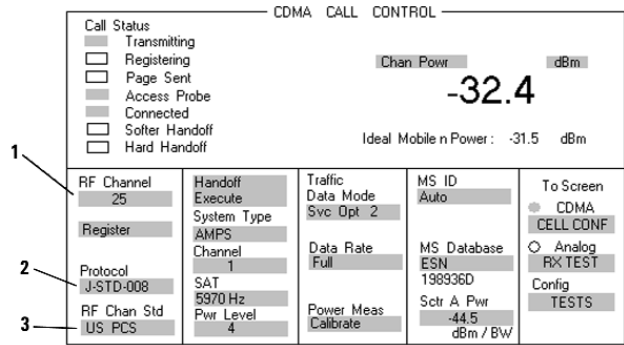

Figure 11. CDMA CALL CONTROL Screen

Setting the CDMA Transmitter Power Test Mode

Access the CDMA TRANSMITTER POWER RANGE TEST screen, see Figure 12.

1. Set the **Closed Loop Pwr Cntl** field (item 1) to **Closed Loop** to begin the test. This field controls the sequence of the “punctured” power control bits. In open loop mode the test set sends alternating 0 and 1 bits.

NOTE: In closed loop mode the test set sends the appropriate power control bits to control the transmitted power level of the phone. Closed loop mode should be active while a call is being connected. Open loop mode is activated after a call has been connected and throughout the remainder of the open loop power control time-response test. For more information, see *Appendix 1—Background on Open and Closed Loop Power Control*.

2. Set the **Drop Timer** field (item 2) to **Off**. This stops the test set from disconnecting the call even when it cannot detect the phone’s transmitted signal. This may occur when the test set is transmitting at the -40 dBm level.

3. Set the **Traffic Data Mode** field (item 3) to **Svc Opt 2** (9600 bps) or **Svc Opt 9** (18800 bps), depending on the standard.

4. Set the **Data Rate** field (item 4) to **Full**.

5. The power meter is able to operate as either a channel-power meter or an average-power meter. Select **Chan Power** (item 5). For this test the channel power meter is used because it gives a channel power reading specific to the reverse channel bandwidth that is occupied by the phone.

6. The **Power Meas** field (item 6) is used to calibrate the channel power meter. Set this field to **Calibrate**, but, before the calibration can proceed, the RF IN/OUT and RF OUT Only ports on the PCS interface, or the RF IN/OUT and DUPLEX OUT ports on the test set, must be connected together with a short RF cable. Refer to the *Agilent 8924C Applications Guide*, chapter 1, pub. number 08924-90021, for assistance in calibration.

7. The sector-A power, **Sctr A Pwr**, field (item 7) is used to change the transmitted power level of the test set in steps of ±20 dB. The power level steps must be entered in whole values and not incremented by turning the knob. Use the up- and down-arrow keys to increment values in 20 dB steps. See *Section 6—Setting Up a 20 dB Increment on the Test Set*.
8. The **Output Attn Hold** field (item 8) is set to **On** only for PCS phones. This field is used to hold the setting of the mechanical relay attenuator in the PCS interface. (For more information see *Appendix 4—Holding the PCS Interface’s RF Attenuator*.)
9. The **Chan Power** reading can be compared to the **Ideal Mobile Power** reading (item 9) to obtain a measure of how effectively the phone operates under the open loop power control.

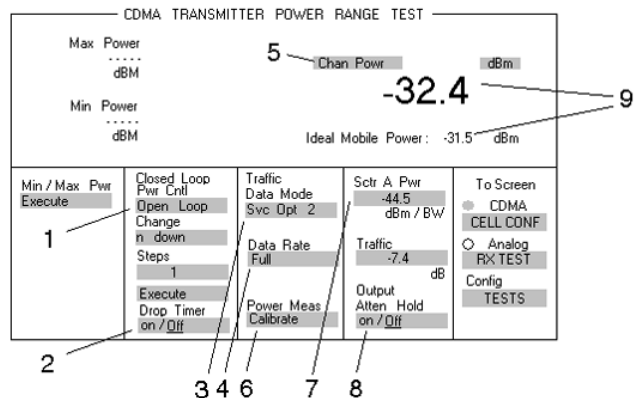

Figure 12. CDMA TRANSMITTER POWER RANGE TEST Screen

Section 6—Setting Up a 20 dB Increment on the Test Set

You can increase or decrease the **Sctr A Pwr** by 20 dB with a press of one button. Listed below are the steps to set up a 20 dB increment adjustment:

1. Go to the CDMA TRANSMITTER POWER RANGE TEST screen, see Figure 13.
2. Move the cursor to the **Sctr A Pwr** field (item 7).
3. Press the **Incr Set** key on the front panel of the test set.
4. Typically **I = 1.00** will appear in the **Sctr A Pwr** field. Using the DATA KEYS, enter the value **20** and then press the knob.
5. By using the up- and down-arrow keys (or turning the knob) on the front panel of the test set, the power will increase or decrease in increments of 20 dB each time an arrow key is pressed (or the knob is turned).

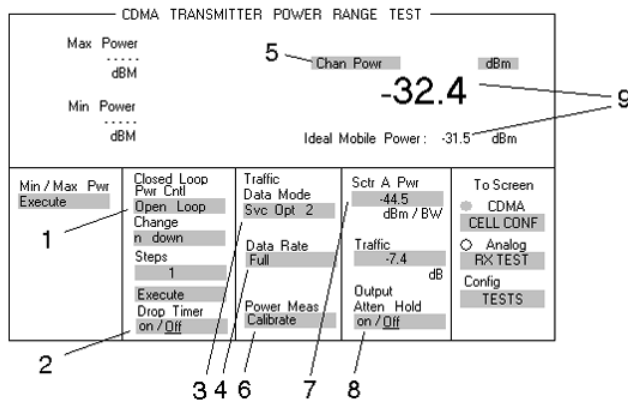

Figure 13. CDMA TRANSMITTER POWER RANGE TEST Screen

Section 7—Determining the Test Set's Trigger Time Delay

In order to perform an accurate open loop power control time-response test, it is important to accurately determine the delay between the trigger signal and the actual power step at the test set's output. Inaccurate delay times will cause the test to start before the power level from the test set has a chance to change. This will often cause the test results to indicate a failure. For details, see *Appendix 5—Trigger Cable and Trigger Signal Description*.

1. Turn off the phone.
2. On the spectrum analyzer:
 - 2a. Press the PRESET key on the front panel.
 - 2b. Press the **Spectrum Analyzer** softkey.
3. On the test set, set the **Sctr A Pwr** field in the CDMA TRANSMITTER POWER RANGE TEST screen to **-40 dBm** (see Figure 13, item 7).
4. For testing PCS phones only, on the test set, set the **Output Atten Hold** field to **on** (see Figure 13, item 8).
5. On the spectrum analyzer:
 - 5a. Press the FREQUENCY key.
 - 5b. Enter the center frequency that the test set (forward channel) is operating on. For example: RF Chan Std = US PCS; RF Channel = 500; forward channel frequency = 1955 MHz.
 - 5c. Press the ENTER key (same as Hz/ μ V/ μ S key).
 - 5d. On the spectrum analyzer, press the SPAN key.

- 5e. Enter 0 Hz, and press the ENTER key.
 - 5f. Press the BW Band Width key.
 - 5g. Enter **3 MHz**, press the ENTER key.
 - 5h. Press the AMPLITUDE key.
 - 5i. Press the **REF LEVEL** softkey and enter **-25 dBm**. Press the ENTER key.
 - 5j. Press the **ATTEN** softkey and ensure it is set to manual, **MAN**. Enter an attenuation of **0 dB** and press the ENTER key.
6. Change the test set's **Sctr A Pwr** field from **-40** to **-60 dBm** to ensure that the setup is correct. The spectrum analyzer display should show a 20 dB drop.
 7. On the spectrum analyzer press the SWEEP key.
 - 7a. Enter **20 ms**.
 - 7b. Press the ENTER key
 8. Set the test set's **Sctr A Pwr** field from **-60** to **-40 dBm**.
 9. On the spectrum analyzer press the TRIG key.
 - 9a. Press the **SWEEP** softkey (next to the display) and set it to single, **SGL**.
 - 9b. Press the **EXTERNAL** softkey.
 10. Change the test set's **Sctr A Pwr** field from **-40** to **-60 dBm**. It typically falls within 15 to 20 ms. Each major graticule line from left to right is 2 milliseconds (typically set trigger delay is between 15 and 20 ms).
 11. On the spectrum analyzer measure the time delay that appears on the display.
 12. Record this delay time, it will be used later in the test procedure.
 13. To reset the spectrum analyzer for another trigger delay measurement:
 - 12a. Press the **FREE RUN** softkey.
 - 12b. Press the **EXTERNAL** softkey.
 14. Change the test set's **Sctr A Pwr** field by a step of 20 dB. Try it from -40 dBm to -80 dBm. The time delays should be almost identical.
 15. When the trigger delay measurements are complete:
 - 15a. Press the AMPLITUDE key.
 - 15b. Press the **ATTEN** softkey.
 - 15c. Choose **AUTO**.

NOTE: The spectrum analyzer is now ready to measure the time delay between the E8285A trigger signal going high and the E8285A RF output level changing 20 dB.

Section 8—Configuring the Spectrum Analyzer and Software

First install the Agilent 89725C software following the instructions in the 85725C user's guide, *Chapter 1—Getting Started*, step 1 “Load the CDMA Measurement Personality.” For best accuracy, you should also perform step 2, the spectrum analyzer's calibration routines. When the 85725C CDMA Measurements Personality software is installed in the spectrum analyzer, the CDMA ANALYZER menu options (see Figure 14) are available.

Setting “CDMA Config” Options

1. Press the MODE key.
 - 1a. Press the **CDMA ANALYZER** softkey.
 - 1b. Press the **CDMA Config** softkey of the CDMA ANALYZER main menu 1 of 3 (see Figure 11). The CDMA Config options sub-menu 1 of 3 appears.
2. Press the **BASE MOBILE** softkey until **MOBILE** is underlined. This tunes the spectrum analyzer to the reverse link of the selected channel.
3. Press the **MS EXT ATTEN** softkey (on sub-menu 1 of 3) enter the value for the attenuation measured from the power splitter and the cables connecting the test set to the spectrum analyzer. This is a positive number since the field is assuming it is an attenuation loss.
 - 3a. 6 dB of attenuation is measured (see *Appendix 3—Determining Cable Connection Losses*).
 - 3b. Enter 6 dB in the **MS EXT ATTEN** return field.
 - 3c. Press the ENTER key on the spectrum analyzer.
4. Press **More 1 of 3** field to obtain CDMA Config sub-menu 2 of 3 (see Figure 12).
5. The **TRIG** field must be set to **EXT** (external). This enables the trigger from the test set.
6. Press **More 2 of 3** softkey to obtain CDMA Config sub-menu 3 of 3 (see Figure 12).
7. Press the **Std/Band** softkey. Then press the softkey that matches the standard you are using. For example, **JSTD-008** for U.S. PCS frequencies.
8. Press the **More 3 of 3** softkey to return to CDMA Config sub-menu 1 of 3 and press the **Main Menu** softkey.

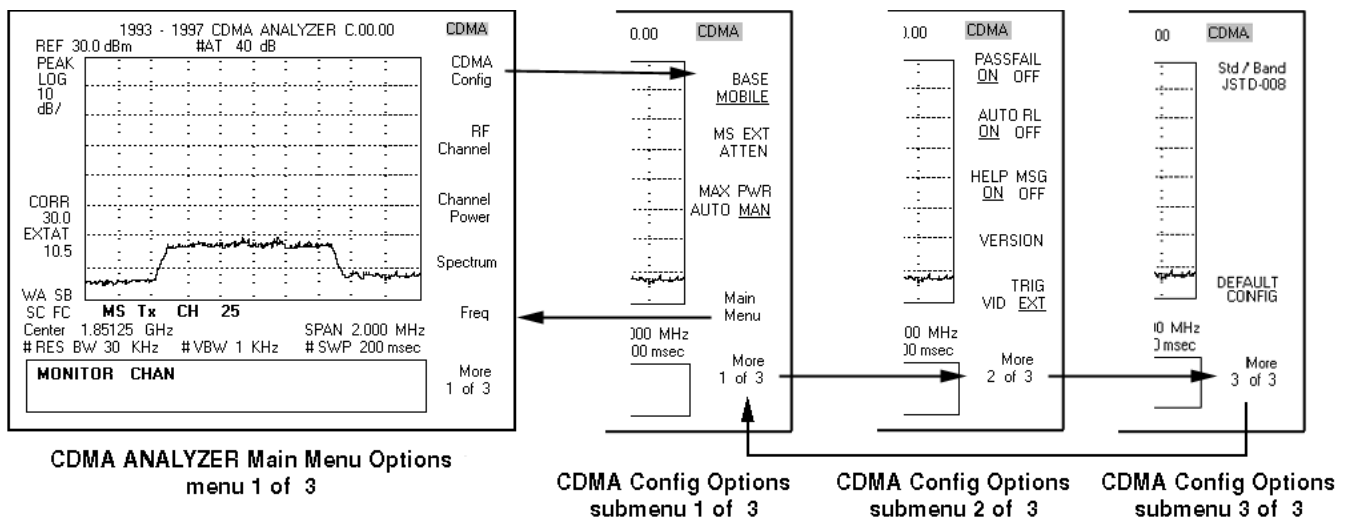

Figure 14. CDMA ANALYZER Main Menu and CDMA Config Menu Options

Setting the RF Channel Function

1. Select the **RF Channel** softkey on the CDMA ANALYZER main menu 1 of 3, the RF Channel options will appear (see Figure 15).
2. Press the **CHANNEL NUMBER** softkey and enter in the correct channel operation number for the phone in this field, then press the **ENTER** key. The **CENTER FREQ** field will automatically update with the center frequency of the entered channel.
3. Press the **Main Menu** softkey to return to the CDMA ANALYZER main menu screen.

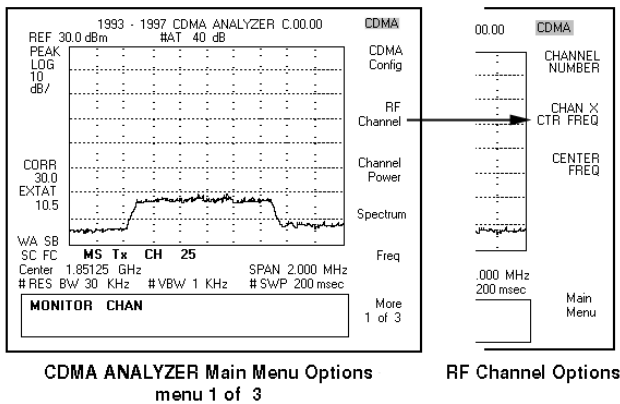

Figure 15. RF Channel Options

Setting the Time Response Function

1. Press the **More 1 of 3** softkey on the CDMA ANALYZER main menu to go to menu 2 of 3 (see Figure 16).
2. Press the **Time Response** softkey to access the time response test functions (see Figure 16).
3. Press the **Open Setup** softkey of the Time Response functions to configure the open loop test setup functions (see Figure 16):
 - 3a. Press the **SWP TIME** softkey. Set the sweep time to 100 ms and then press the **ENTER** key. (100 ms is the measurement time specified by IS-98-A.)
 - 3b. The **DELTA PWR** field determines the step value at which the mask limits change with respect to each trigger signal. 20 dB is the default value of this field (20 dB is the step specified by IS-98-A).

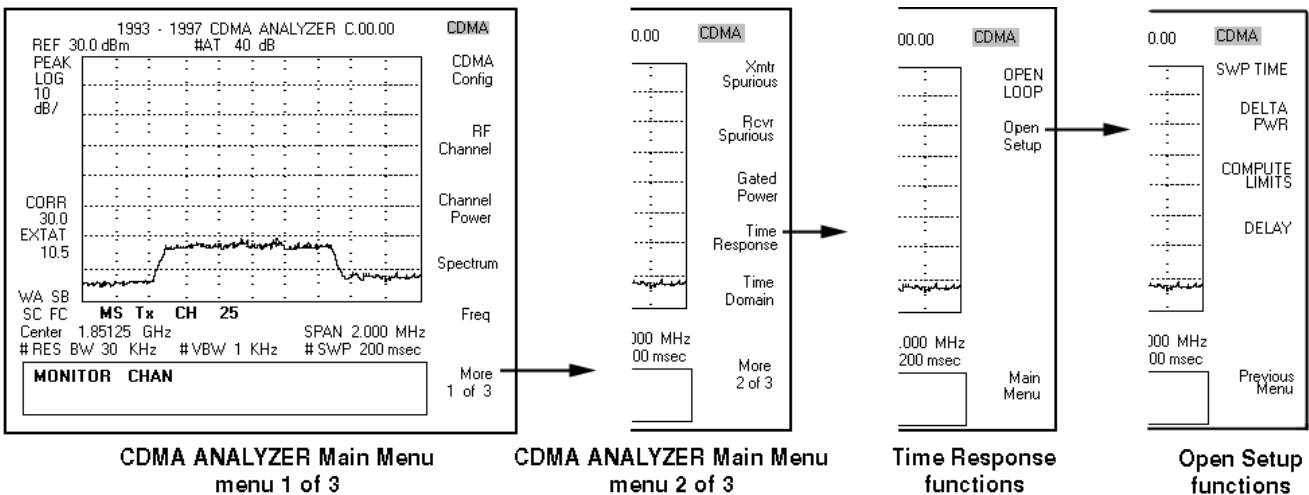

Figure 16. Time Response Function

- 3c. Press the **DELAY** softkey. Enter the trigger delay time measured in *Section 8—Determining Trigger Time Delay*. The delay time is entered in microseconds, for example: 17 ms delay time = 17,000 μ s. Press the ENTER key twice. It is important to enter an accurate delay time in order to obtain accurate test results. The test may fail frequently if the trigger does not occur at the time of power transitions.
- 3d. Press the **Previous Menu** softkey to return to the Time Response menu screen.

References

- *Agilent Technologies 89725C Measurements Personality User's Guide*, pub. number 85725-90010
- For Agilent Technologies 859XE setup and configuration refer to the *User's Guide*, pub. number 08590-90301.

Appendix 1—Background on Open and Closed Loop Power Control

The effectiveness of CDMA as a method to increase call capacity is partially determined by how effective the transmitted power of each mobile can be accurately controlled and minimized. The goal of the mobile is to transmit its signal with the least amount of power capable of producing a detectable signal at the base station; any more power will simply be added noise to the system. In order to accurately control the mobile's power (reverse link), two methods are used: open loop power control and closed loop power control.

Open Loop

The open loop power control process is performed when the phone is in an idle state (not on a call). Open loop power control assumes that the path loss is the same on the reverse path as it is on the forward path. The mobile can determine the correct transmit power (reverse link) by monitoring the base station's transmit power (forward link) and subtracting a constant. The open loop power control response for cellular and PCS frequencies are described by the following equations:

Cellular Equation

$$\begin{aligned} &\text{Receive Power (Forward Link) + Transmit Power} \\ &\text{(Reverse Link) + Nominal Power + Initial Power} \\ &= -73 \text{ dBm} \end{aligned}$$

PCS Equation

$$\begin{aligned} &\text{Receive Power (Forward Link) + Transmit Power} \\ &\text{(Reverse Link) + Nominal Power + Initial Power} \\ &= -76 \text{ dBm} \end{aligned}$$

Closed Loop

Closed loop power control accompanies the open loop power control process. The base station monitors the received signal from the mobile and determines if the signal is "just good enough to maintain a link." Every 1.25 milliseconds or 800 times a second the base station commands the mobile to raise or lower its transmit power by a step of 1 dB based on the signal it received from the mobile. Therefore, the power transmitted from the mobile is never constant for more than 1.25 ms.

The base station sends the closed loop power control instruction to the mobile by replacing a bit of voice data with a power control bit. For instance, if a one bit is received the mobile knows to reduce its power by 1 dB, and if a zero bit is received the mobile knows to increase its power by 1 dB. This process is called "puncturing."

Appendix 2—The Effect of Closed Loop Control on the Open Loop Test

Since this test is only concerned with the open loop response it would be ideal to eliminate the effects of the closed loop power control on the reverse power transmission. This is not entirely possible. Due to the various design limitations that phone manufacturers have in their products, the test set is unable to tell the phone to turn off the closed loop control.

The open loop test that is described in this paper is not exclusively open loop controlled, the closed loop control is still present because the phone is on a call. The test set has the capability of going into a “virtual open loop mode” by alternating the power control bits (between digital 0 and 1). This gives the appearance of being exclusively in open loop power control mode, but with an error of ± 1 dB at best.

This can cause a problem when the base station is transmitting near the noise floor. Since there is no form of error correction associated with the “punctured” power control bits, they are easily received in error. Once the forward link approaches the noise floor, the Frame Error Rate (FER) increases, which will increase the probability of receiving consecutive similar power-control bits. At such low signal levels this error could be enough to cause a dropped call or failure of the open loop time-response test.

Simply by monitoring the FER you can tell when the noise floor is compromising your measurements. The noise floor is not standard, it can vary from time to time and location to location. Just because your phone passes the tests in one location doesn't mean that the phone will pass in a different location or at a different time. Therefore, it is very important to have your phone properly shielded from outside noise and interference during testing.

Appendix 3—Determining Cable Connection Losses

In order to obtain accurate power measurements a few steps need to be taken. First, always calibrate the channel power on the test set when you have powered down the test set or if significant changes have been made to the configuration of the test set (channel changes, cellular to PCS operation, and so forth).

Second, you must account for losses that have occurred through the transmission medium between the connected devices. Since you are using a power splitter and two cables, these losses need to be taken out of the power transmission process. The test set allows you to enter an RF level offset. The test set transmits its signal at a level above or below the entered sector power, depending on the sign (+ or -) of the attenuation entered into the **RF Level Offset** field. (Refer to *Section 6—Setting Up a 20 dB Increment on the Test Set*; and *Section 7—Determining Test Set Trigger Time Delay*.)

External Power Meter Method

In order to determine the attenuation of the power splitter and the two cables, an external power meter can be used. Listed below are the steps you need to take to find your RF power compensation:

1. Zero the power meter.
2. Connect the power meter directly to the test set's DUPLEX OUT port; or, the PCS interface's RF OUT Only port.

3. On the CONFIGURE screen:
 - 3a. Set **RF Level Offset** field to **Off**.
 - 3b. Set the **Output Port** field to **Duplex** for cellular band, or **only** for PCS.
4. Go to the CDMA CALL CONTROL screen:
 - 4a. If no PCS interface is used, set **Sctr A Pwr** field to **dBm**.
 - 4b. If a PCS interface is used, set to **-11 dBm**.
5. With the power meter, measure the power out of the test set.
6. Connect the cables and splitter to the DUPLEX port, or RF OUT Only for the PCS interface. Include every connection from the test set up to but not including the cellular phone. This includes a car kit or break out box if used.
7. With the power meter, measure the power at the end of the cables and splitter.
8. Subtract the second measurement from the first to obtain your RF level offset.

Using the Agilent 8924C Test Set

To determine the attenuation of the power splitter and the cables, the test set can be used. Refer to "Determining RF Path Loss" in Chapter 1 of the *Agilent Technologies 8924C Application Guide*, pub. number 08924-90021.

Appendix 4—Holding the PCS Interface’s RF Attenuator

This appendix applies only if an Agilent 83236B PCS Interface is used.

A mechanical attenuator is used in the PCS interface. Mechanical attenuators when switched in and out of operation can produce transient responses as they are relays that open and close. While a relay is in an open state, the open loop power control of the mobile notices a loss of power from the base station and starts transmitting the reverse signal at a higher power level.

When the mechanical attenuator completes its transition (typically 10 ms to 50 ms) the forward power returns to a higher value and the mobile’s open loop power control notices that it is transmitting the reverse signal at too high a power and starts to lower its signal strength. This variation is undesirable for the open loop timing measurement.

To correct this problem, the mechanical attenuator in the PCS interface is set in a fixed state, and the RF output level is varied using the transit-free electronic attenuator in the test set. (The fixed state is selected when the **Output Atten Hold** field in the CDMA TRANSMITTER POWER RANGE TEST screen is set to **on**.)

The maximum power that the test set and the PCS interface will be transmitting in this test will be -40 dBm so that is the attenuator hold level. Once held, RF output levels down to approximately 50 dB lower than the “hold” level are accurate. However, output levels higher than the “hold” level are inaccurate.

Appendix 5—Trigger Cable and Trigger Signal Description

Making a Trigger Cable

Components

- Shielded coaxial cable approximately 3 ft (1 m) long
- Male BNC connector with solder pot terminal and ground lug
- 15-pin male subminiature D-connector with solder pot terminals
- 15-pin subminiature D-connector hood
- Heat shrink tubing or insulator

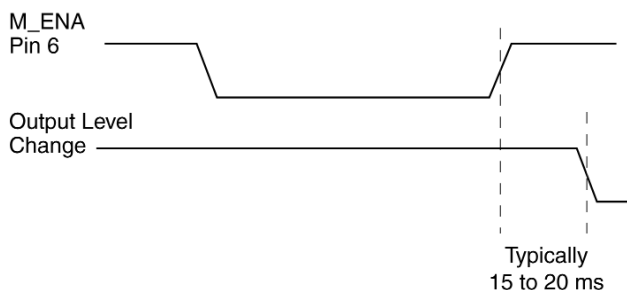

Figure 17. Trigger Delay Response

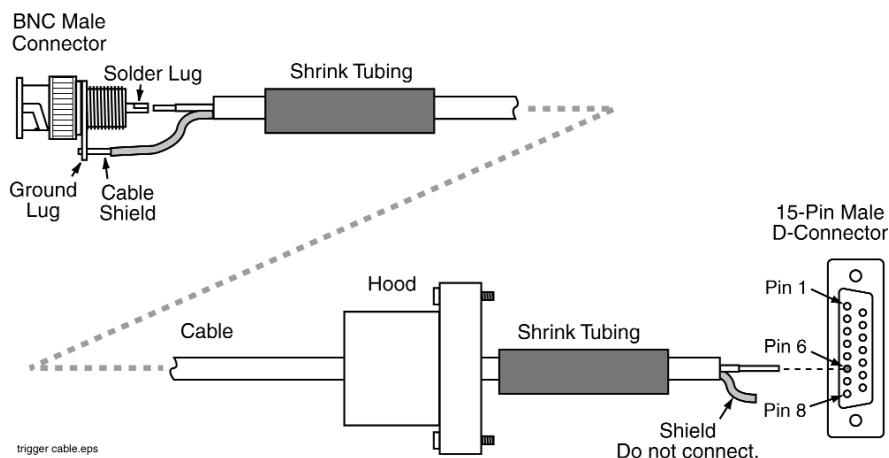

Figure 18. Trigger Cable Assembling

Procedure

1. Solder the cable's center-conductor to pin 6 of the D-connector (see Figure 18).
2. Solder the other end of the center conductor to the BNC center pin.
3. Solder the cable shield to the BNC ground lug.
4. Shrink wrap the D-connector so it will not contact any pins.
5. Shrink wrap the conductor and soldered pins, and install the hood on the D-connector.

Trigger Signal Description

Approximately 15 to 20 milliseconds¹ (ms) before the RF output power changes on the test set, the trigger signal on the AUX CONTROL connector pin 6 goes high, see Figure 17. The rise time for the trigger transition from low to high is negligible, approximately 600 nanoseconds (ns).

Reference

For more information on the auxiliary control port refer to: *Agilent 8924C Reference Guide*, pub. number 08924-90053.

1. To measure the precise delay time for your test set, refer to Section 7—*Determining the Test Set's Trigger Time Delay* in this product note.

Agilent Technologies' Test and Measurement Support, Services, and Assistance

Agilent Technologies aims to maximize the value you receive, while minimizing your risk and problems. We strive to ensure that you get the test and measurement capabilities you paid for and obtain the support you need. Our extensive support resources and services can help you choose the right Agilent products for your applications and apply them successfully. Every instrument and system we sell has a global warranty. Support is available for at least five years beyond the production life of the product. Two concepts underlie Agilent's overall support policy: "Our Promise" and "Your Advantage."

Our Promise

"Our Promise" means your Agilent test and measurement equipment will meet its advertised performance and functionality. When you are choosing new equipment, we will help you with product information, including realistic performance specifications and practical recommendations from experienced test engineers. When you use Agilent equipment, we can verify that it works properly, help with product operation, and provide basic measurement assistance for the use of specified capabilities, at no extra cost upon request. Many self-help tools are available.

Your Advantage

"Your Advantage" means that Agilent offers a wide range of additional expert test and measurement services, which you can purchase according to your unique technical and business needs. Solve problems efficiently and gain a competitive edge by contracting with us for calibration, extra-cost upgrades, out-of-warranty repairs, and on-site education and training, as well as design, system integration, project management, and other professional services. Experienced Agilent engineers and technicians worldwide can help you maximize your productivity, optimize the return on investment of your Agilent instruments and systems, and obtain dependable measurement accuracy for the life of those products.

By internet, phone, or fax, get assistance with all your test and measurement needs.

Online Assistance

www.agilent.com/find/assist

Phone or Fax

United States:

(tel) 1 800 452 4844

Canada:

(tel) 1 877 894 4414

(fax) (905) 206 4120

Europe:

(tel) (31 20) 547 2323

(fax) (31 20) 547 2390

Japan:

(tel) (81) 426 56 7832

(fax) (81) 426 56 7840

Latin America:

(tel) (305) 269 7500

(fax) (305) 269 7599

Australia:

(tel) 1 800 629 485

(fax) (61 3) 9210 5947

New Zealand:

(tel) 0 800 738 378

(fax) (64 4) 495 8950

Asia Pacific:

(tel) (852) 3197 7777

(fax) (852) 2506 9284

Product specifications and descriptions in this document subject to change without notice.

Copyright © 1999, 2000 Agilent Technologies

Printed in U.S.A. 10/00

5966-3877E

For related product information visit our website at:

www.agilent.com/find/8924support/



Agilent Technologies

Innovating the HP Way